

# Steam Turbine

## Introduction to the Steam Turbine

De Laval, Parsons and Curtis developed the concept for the steam turbine in the 1880s. Modern steam turbines use essentially the same concept but many detailed improvements have been made in the intervening years mainly to improve turbine efficiency.

Steam turbines are used in all of our major coal fired power stations to drive the generators or alternators, which produce electricity. The turbines themselves are driven by steam generated in 'Boilers' or 'Steam Generators' as they are sometimes called.

Energy in the steam after it leaves the boiler is converted into rotational energy as it passes through the turbine. The turbine normally consists of several stages with each stage consisting of a stationary blade (or nozzle) and a rotating blade. Stationary blades convert the potential energy of the steam (temperature and pressure) into kinetic energy (velocity) and direct the flow onto the rotating blades. The rotating blades convert the kinetic energy into forces, caused by pressure drop, which results in the rotation of the turbine shaft. The turbine shaft is connected to a generator, which produces the electrical energy. The rotational speed is 3000 rpm for Australian (50 Hz) systems and 3600 for American (60 Hz) systems.

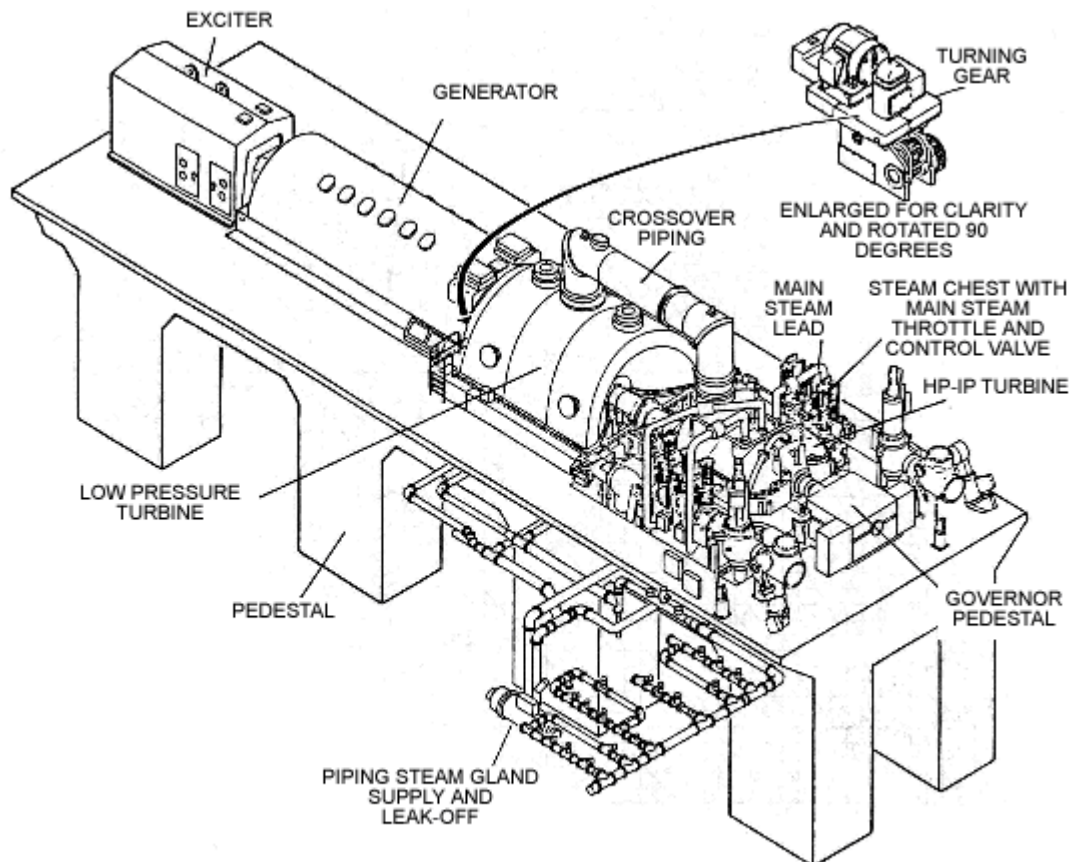

**A TYPICAL POWER STATION STEAM TURBINE AND ITS EXTERNAL EQUIPMENT**

## Steam Turbines

In a typical larger power stations, the steam turbines are split into three separate stages, the first being the High Pressure (HP), the second the Intermediate Pressure (IP) and the third the Low Pressure (LP) stage, where high, intermediate and low describe the pressure of the steam.

After the steam has passed through the HP stage, it is returned to the boiler to be re-heated to its original temperature although the pressure remains greatly reduced. The reheated steam then passes through the IP stage and finally to the LP stage of the turbine.

A distinction is made between "impulse" and "reaction" turbine designs based on the relative pressure drop across the stage. There are two measures for pressure drop, the pressure ratio and the percent reaction. Pressure ratio is the pressure at the stage exit divided by the pressure at the stage entrance. Reaction is the percentage isentropic enthalpy drop across the rotating blade or bucket compared to the total stage enthalpy drop. Some manufacturers utilise percent pressure drop across stage to define reaction.

Steam turbines can be configured in many different ways. Several IP or LP stages can be incorporated into the one steam turbine. A single shaft or several shafts coupled together may be used. Either way, the principles are the same for all steam turbines. The configuration is decided by the use to which the steam turbine is put, co-generation or pure electricity production. For co-generation, the steam pressure is highest when used as process steam and at a lower pressure when used for the secondary function of electricity production.

A typical power station steam turbine and its external equipment; and

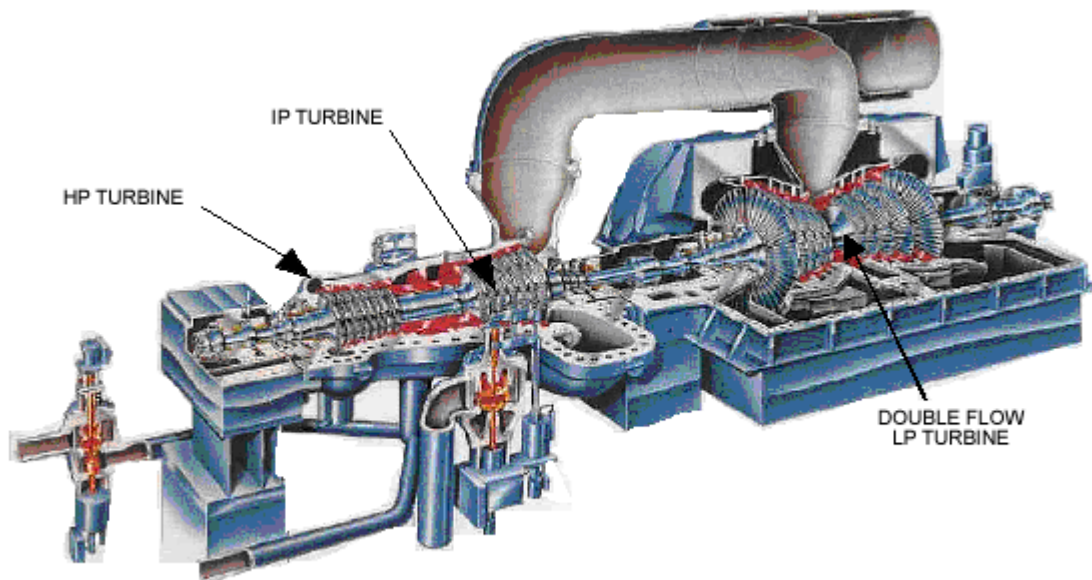

**VIEW OF THE INTERNALS OF A TYPICAL POWER STATION STEAM TURBINE**

## Nozzles and Blades

Steam enthalpy is converted into rotational energy as it passes through a turbine stage. A turbine stage consists of a stationary blade (or nozzle) and a rotating blade (or bucket). Stationary blades convert the potential energy of the steam (temperature and pressure) into kinetic energy (velocity) and direct the flow onto the rotating blades. The rotating blades convert the kinetic energy into impulse and reaction forces caused by pressure drop, which results in the rotation of the turbine shaft or rotor.

Steam turbines are machines which must be designed, manufactured and maintained to high tolerances so that the design power output and availability is obtained. They are subject to a number of damage mechanisms, with two of the most important being:

Erosion due to moisture. The presence of water droplets in the last stages of a turbine causes erosion to the blades. This has led to the imposition of an allowable limit of about 12% wetness in the exhaust steam; and Solid particle erosion. The entrainment of erosive materials from the boiler in the steam causes wear to the turbine blades.

## Cogeneration Cycles

In cogeneration cycles, steam is typically generated at a higher temperature and pressure than required for a particular industrial process. The steam is expanded through a turbine to produce electricity and the resulting extractions at the discharge are at the temperature and pressure required by the process.

Turbines can be condensing or non-condensing design typically with large mass flows and comparably low output. Traditionally, pressures were 6.21 MPa and below with temperatures 441° C or lower, although the trend towards higher levels of each continues.

There are now a considerable number of co-generation steam turbines with initial steam pressures in the 8.63 to 10 MPa range and steam temperatures of 482 to 510° C.

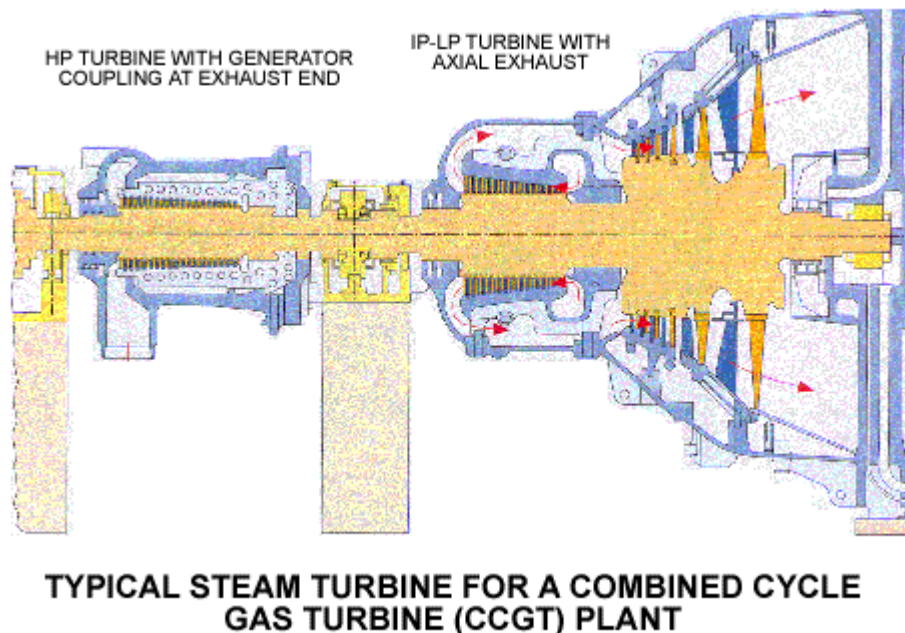

## Bearings and Lubrication

Two types of bearings are used to support and locate the rotors of steam turbines:

Journal bearings are used to support the weight of the turbine rotors. A journal bearing consists of two half-cylinders that enclose the shaft and are internally lined with Babbitt, a metal alloy usually consisting of tin, copper and antimony; and

Thrust bearings axially locate the turbine rotors. A thrust bearing is made up of a series of Babbitt lined pads that run against a locating disk attached to the turbine rotor.

High-pressure oil is injected into the bearings to provide lubrication. The oil is carefully filtered to remove solid particles. Specially designed centrifuges remove any water from the oil.

## Shaft Seals

The shaft seal on a turbine rotor consist of a series of ridges and groves around the rotor and its housing which present a long, tortuous path for any steam leaking through the seal. The seal therefore does not prevent the steam from leaking, merely reduces the leakage to a minimum. The leaking steam is collected and returned to a low-pressure part of the steam circuit.

## Turning gear

Large steam turbines are equipped with "turning gear" to slowly rotate the turbines after they have been shut down and while they are cooling. This evens out the temperature distribution around the turbines and prevents bowing of the rotors.

## Vibration

The balancing of the large rotating steam turbines is a critical component in ensuring the reliable operation of the plant. Most large steam turbines have sensors installed to measure the movement of the shafts in their bearings. This condition monitoring can identify many potential problems and allows the repair of the turbine to be planned before the problems become serious.

Reference

**Web site :** <http://www.energy.qld.gov.au/electricity/infosite/index.htm>